

- (A) WATER FILLER CAP, FRESH WATER
- (B) OIL FILLER CAP, ENGINE
- (C) OIL DIP STICK, ENGINE LEFT OR RIGHT SIDE MOUNTED
- (D) ECU CONTROL UNIT
- (E) OIL DRAIN (WITH PPE), ENGINE Ø125
- (F) OIL FILTER MAN
- (G) OIL FILTER BYPASS
- (H) LIFTING EYE
- (I) WATER DRAIN, FRESH WATER
- (L) WATER DRAIN, SEA WATER
- (K) AIR FILTER
- (M) FUEL FILTER
- (N) HOT WATER OUTLET Ø16
- (O) HOT WATER INLET Ø16
- (P) STRAINER SEA WATER
- (Q) OIL DIP STICK DRIVE GUNDER COVER
- (R) CENTRE OF GRAVITY
- (S) WATER INLET DRIVE
- (T) OIL DRAIN DRIVE (BEHIND ADAPTER)
- (U) FUEL INLET CONNECTION Ø10
- (V) FUEL RETURN TO TANK Ø10
- (X) ENGINE STOP
- (Y) CRANK CASE VENTILATION
- (Z) EXHAUST RISER Ø102 (4" OPTION)
- AA X-MEASUREMENT SEE 7742299-6
- (AB) TIE BAR (TWIN INSTALLATION)
- (AC) EXTRA ALTERNATOR (OPTION)
- (AD) SEA WATER PUMP

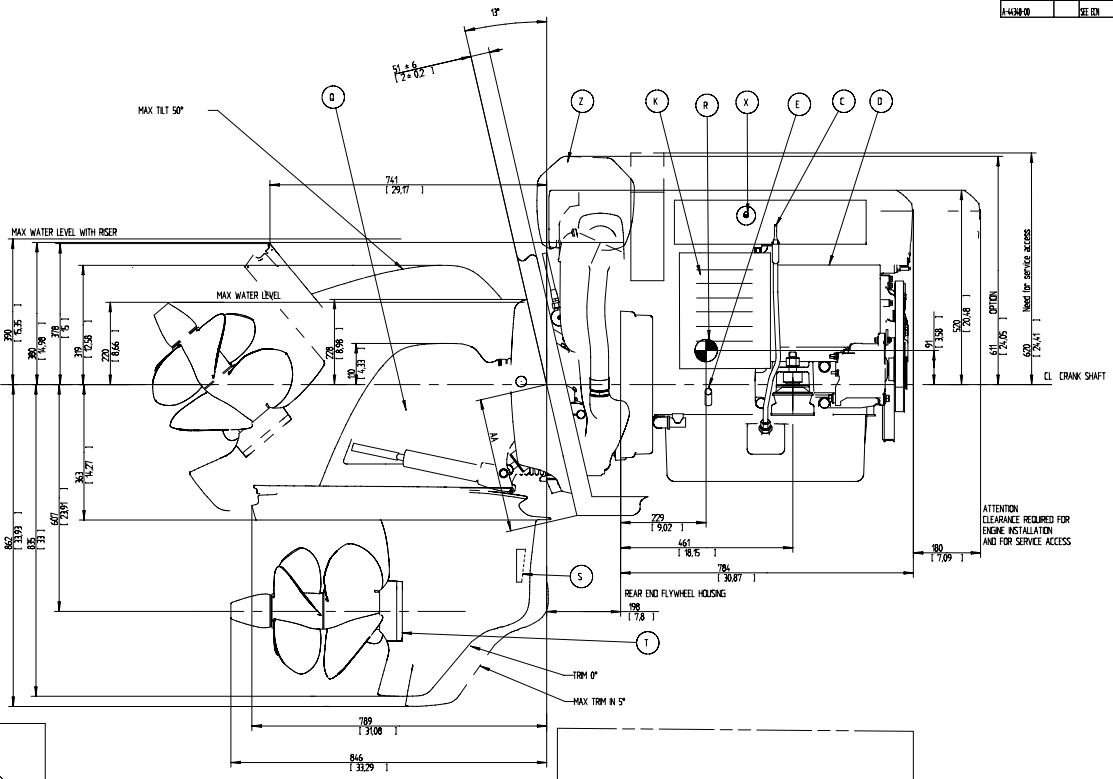

ATTENTION  
CLEARANCES REQUIRED FOR  
ENGINE INSTALLATION  
AND FOR SERVICE ACCESS

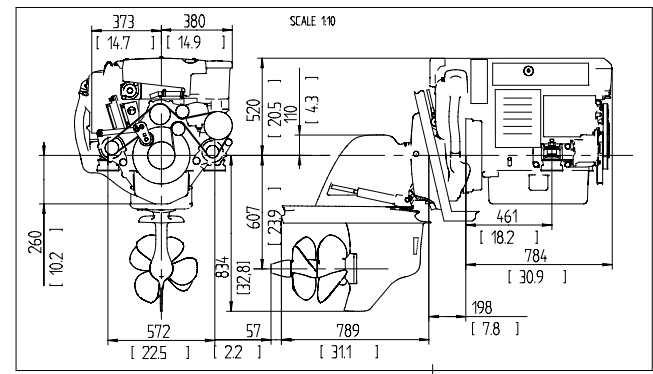
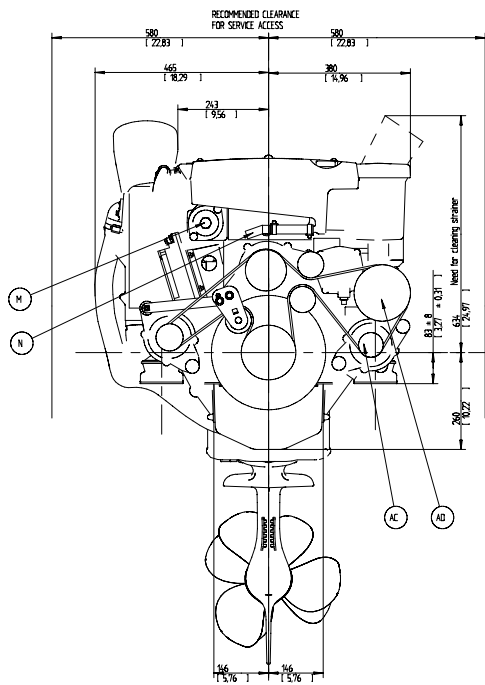
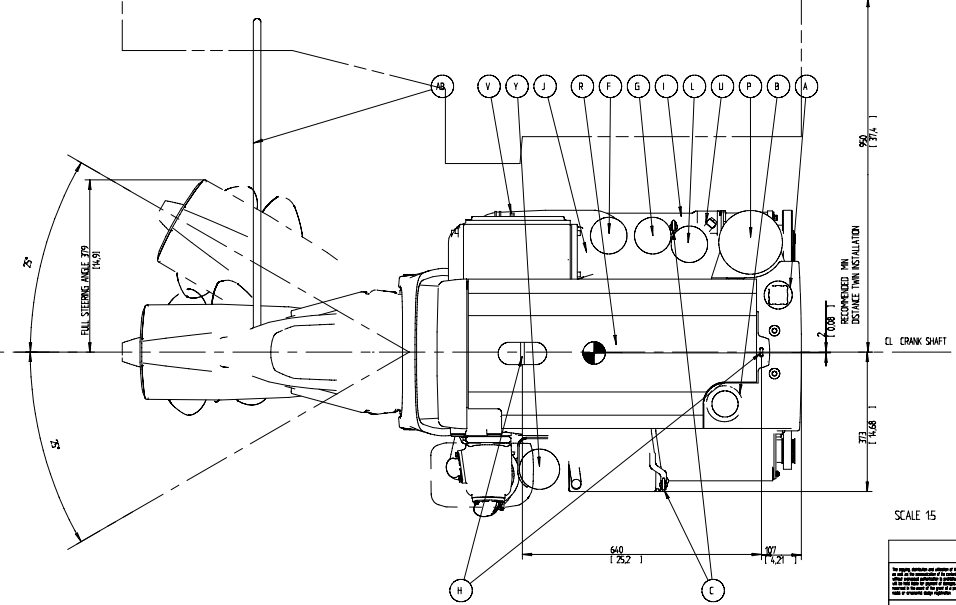
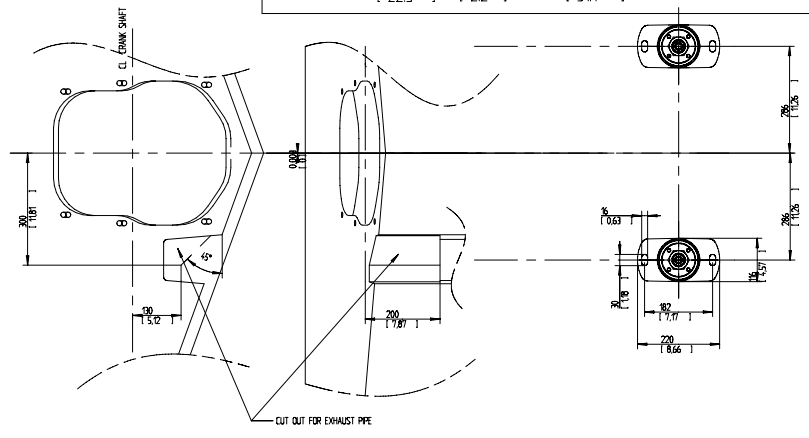

OIL DIP STICK LEFT SIDE STANDARD  
CAN BE MOVED TO RIGHT SIDE

SCALE 1:5

VOLVO PENTA		SMALL DIESEL AND GASOLINE ENGINES FOR MARINE USE	
ENGINE		DA / AD-DRIVE DP-H	
DRAWING		3521862	
3521862		01	